

Swarm A20

Auto-Darkening Welding Helmet



Swarm A-20

Welding Processes

- SMAW / MMA (Stick)
- MIG / MAG (GMAW)
- Manual Plasma Cutting (PAC)
- Air Carbon Arc and Cutting (CAC-A)
- TIG Welding

The lightweight Swarm A20 is a heavyweight when it comes to performance and flexibility. Using an advanced auto-darkening filter (ADF), Swarm A20's externally selectable shade range from 9–13 tackles the most demanding welding applications. Further adjustments to delay and sensitivity settings can be made easily with dials inside the helmet. A handy grind setting, also found on the external knob, allows quick attention to finishing work.

With a streamlined shell design, 1/1/1/2 CE optical clarity, and replaceable, long-lasting battery – Swarm A20 is the perfect solution for welders looking to improve weld quality.

- ADF viewing area: 93 x 43 mm (3.6 x 1.7 in.)
- Shade range: DIN 9–13 (adjustable)
- Grind Mode
- CE Optical class: 1/1/1/2
- Arc sensors: 2
- Fully-adjustable delay and sensitivity settings
- Replaceable CR2032 batteries (1)
- Low battery indicator LED
- ADF test button

Visit esab.com for more information.



*Lightweight, streamlined shell design
with 1/1/1/2 CE optical clarity.*

Swarm A20 Welding Helmet

Specifications	
Viewing Area	93 x 43 mm (3.6 x 1.7 in.)
Active Lens Shade	9–13 (Adjustable)
Passive Lens Shade	4
Power Supply	1 CR2032 batteries, replaceable
Arc Sensors	2
Switch Time (Light to Dark)	0.1 ms
CE Optical Classification	1/1/1/2
Standards and Certifications	CE: EN175; EN379; EN166 ANSI: Z87.1 CSA: Z94.3 Brazil CA
Weight	520g (1.1 lb)

* Grind setting also available.

Ordering Information	
Description	Part Number
Swarm A20 Helmet	0700102043

Delivery includes: Full helmet assembly

Spare Parts		
3	Swarm A20 Auto Darkening Filter (ADF)	0700102039
4	Swarm A10 / A20 Inner Cover Lens 5 PCS	0700102038
5	Swarm A10 / A20 ADF Retainer	0700102035

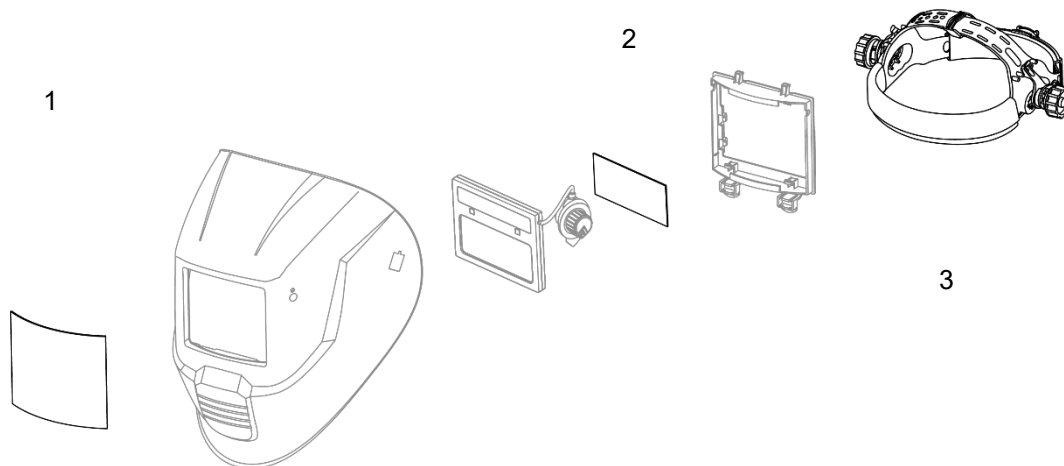

ESAB / esab.com

